

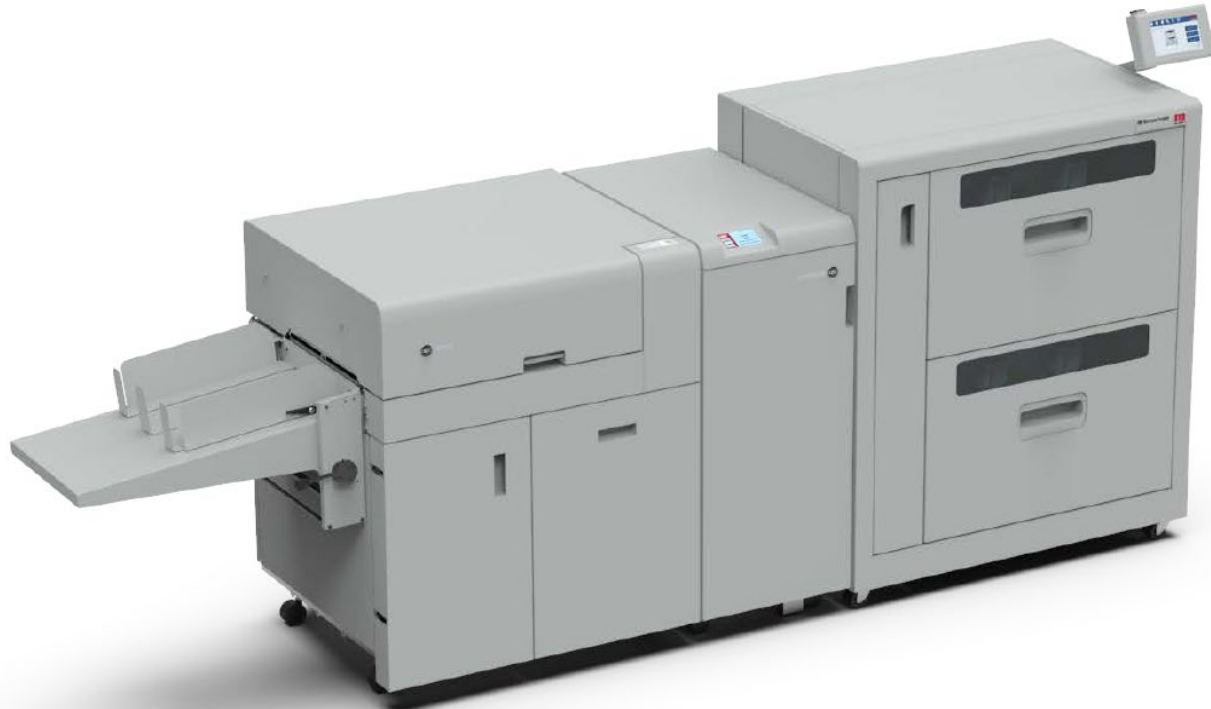

eWire VFX & StreamPunch VFX Installation Instructions



Part Number: 7723674
Revision number: B1
Issue Date: June 2021

This page intentionally left blank.

Installation Instructions

Section Content



Installation Instructions	3
8.1. Installation Prerequisites	2
8.1.1 Power Requirements	2
8.1.2 Die Requirements	2
8.1.3 Space Recommendations	2
8.2. StreamPunch VFX Installation	3
8.2.1 Required Parts	3
8.2.2 Unpacking	4
8.2.3 Docking Procedure	5
8.2.4 Connection and Powering the StreamPunch VFX	7
8.3. eWire VFX Installation	9
8.3.1 Check the Packing List	9
8.3.2 Upstream Device Requirements	9
8.3.3 Required Tools	9
8.3.4 Remove the Packing Materials	9
8.3.5 Inspect for Damage	14
8.3.6 Prepare and Dock	14
8.3.7 Vertical Alignment and Leveling of the eWire VFX	17
8.3.8 Connections and Powering the eWire VFX	18
8.3.9 Configure the eWire VFX	19
8.3.10 Run eWire VFX	19
8.3.11 User Manual	19

8.1. Installation Prerequisites

8.1.1 Power Requirements

Verify that sufficient power is available for the GBC eWire VFX and StreamPunch VFX. They each require a separate, grounded 115/60Hz VAC power socket in the USA or 230/50Hz in UK and Europe.

USA Plug Configuration:

 <p>Male Plug NEMA 5-15P</p>	 <p>Female Receptacle NEMA 5-15R</p> <p>This receptacle will also accept the 15A/125V 2-pole plug above.</p>	<p>15 amp, 125 volt 2-Pole 3-Wire Grounding</p> <p>Most common household and commercial plug. Uses include electric drills, clothes washers and gas dryers, window air conditioners, refrigerators and freezers. ½ hp rating</p> <p>Notice the wide blade is the white or neutral pole.</p>
---	---	---

8.1.2 Die Requirements

If installing the eWire VFX, an eWire die will be needed to punch the correct size holes in the StreamPunch VFX. Two options are available.

DIE, eWire, Rnd	7723484A
DIE, eWire, Sq	7723485A

8.1.3 Space Recommendations

In addition to the space requirements shown in the diagrams, for the configuration being installed, there should be a minimum of 78 inches (1980mm) clearance from the floor to the nearest overhead obstruction.

VFX Feeder + StreamPunch VFX + eWire VFX+ Output tray/Mini Stacker

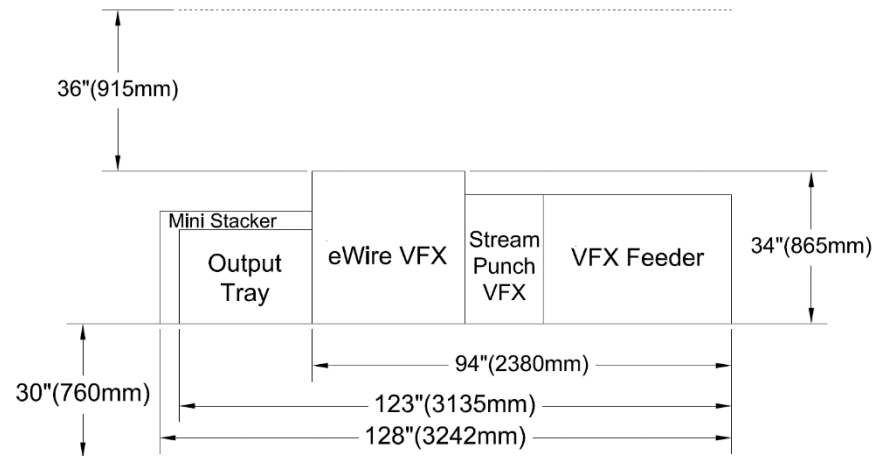



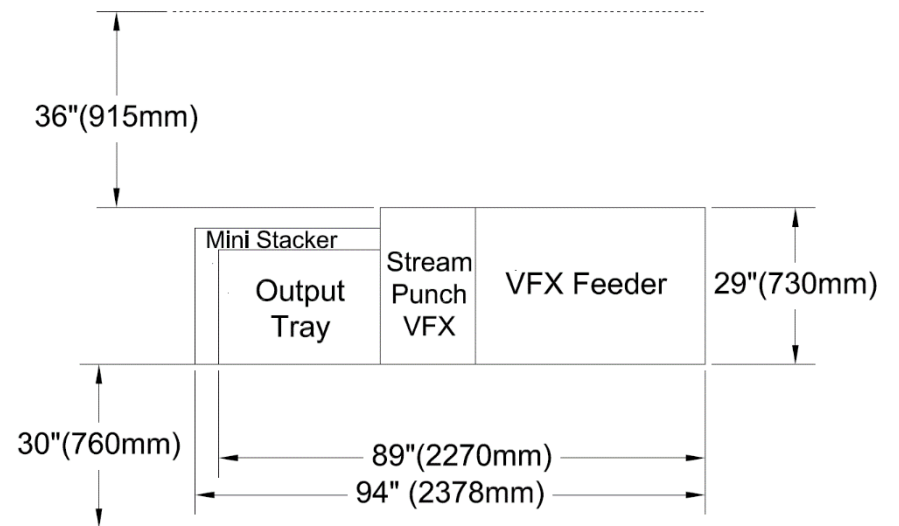

VFX Feeder + StreamPunch VFX + Output Tray/Mini Stacker





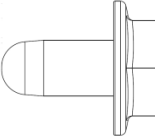
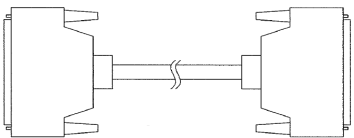

8.2. StreamPunch VFX Installation

8.2.1 Required Parts

The StreamPunch VFX is shipped with an installation kit containing the following components.

No.	Description	Picture	Qty
1	Power Cord (US) 6ft (1.8m) long		1
2	Power Cord (UK) 8ft (2.4m) long		1
3	Power Cord (EU) 8ft (2.4m) long		1
4	Power Cord (Swiss) 8ft (2.4m) long		1
5	Screw, Round tip, M4 x 8		12
6	Cable Assembly, Interface (37 pin)		2

7	Downstream Docking Bracket, Rear		1
8	Downstream Docking Bracket, Front		1
9	Upstream Exit Docking Bracket for Plockmatic VFX		1
10	Upstream Locking Bracket device (picture just for reference – Already installed on StreamPunch VFX)		

8.2.2 Unpacking

Remove plastic wrap and straps from the package using a cutting tool

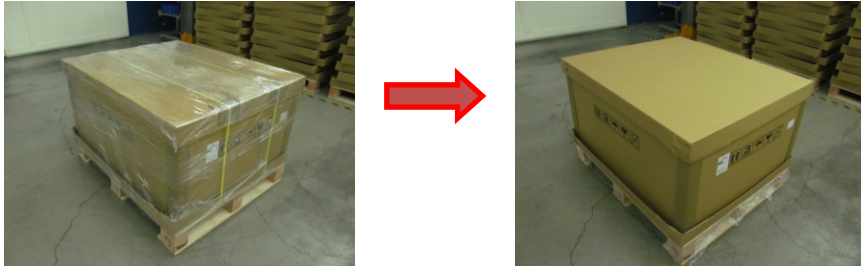

Remove the tape holding the plastic bag closed and pull back the bag exposing the casters



Lift of the lid and remove the installation kit and set it aside, it contains the items in section 1



Cut the corners of the lower box and with two people slide the punch so that the wheels overhang the edge

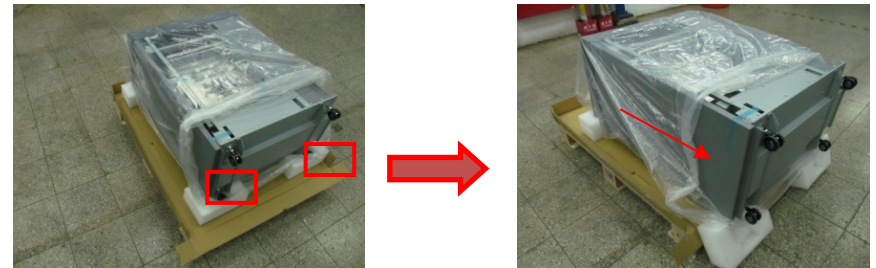

Remove the four inner and 4 outer corner guards and then lift the shell straight up to remove it

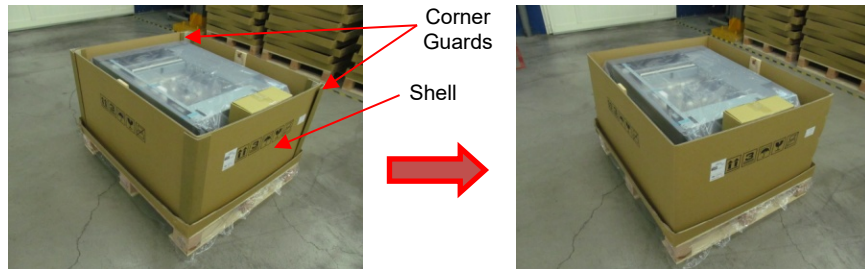

With two people, lift the punch holding the top cover so that it stands upright on the casters



Remove the plastic cover, tape, and foam from all locations

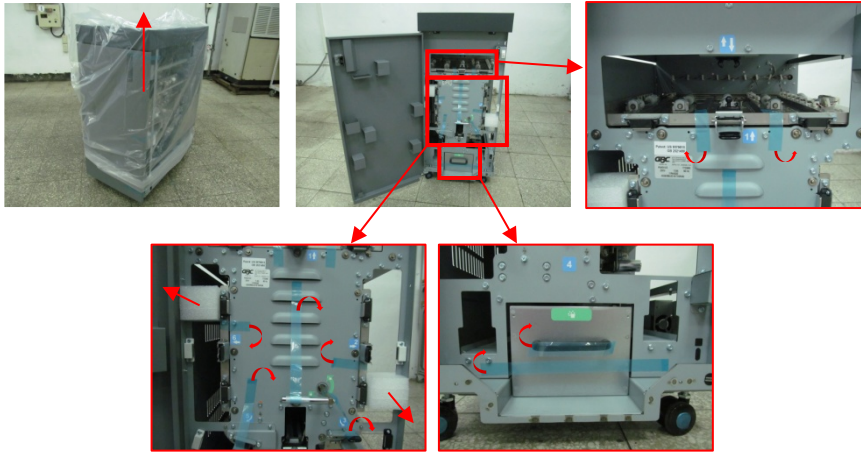

8.2.3 Docking Procedure

Before docking the machine, adjust the casters so that the paper path is the same height as the upstream unit (710.5mm from ground) and the top of the machine is level.

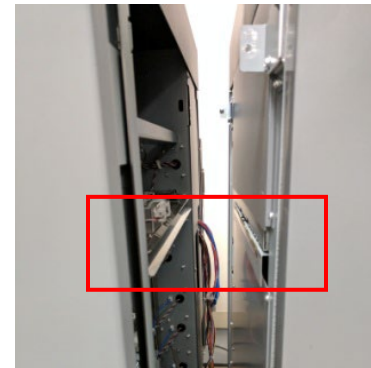
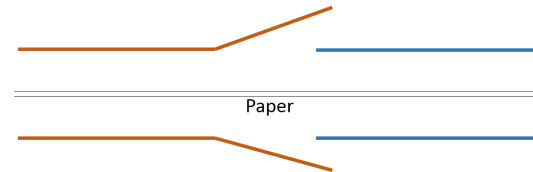

To adjust the casters, loosen the top nut on the caster, and rotate the wheel by hand. Clockwise to lower, counterclockwise to raise. Once the desired height is achieved, tighten the top nut to secure the caster.

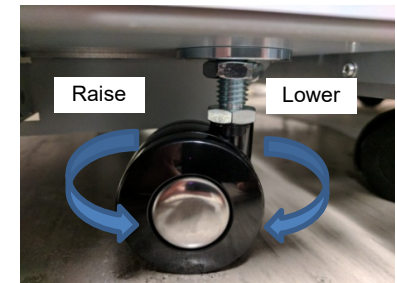

Install the 2 Part Upstream Docking Bracket on the Plockmatic VFX.

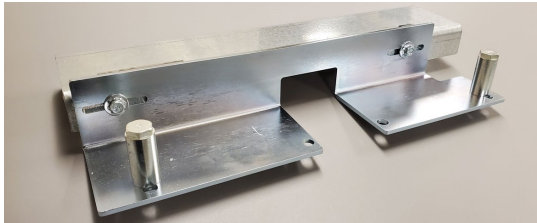

Item 9

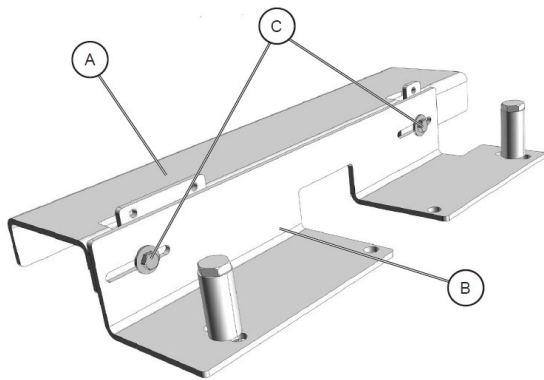

Retrieve the Docking Bracket from one of the installation kits shipped with the Booklet Maker. The Docking bracket is composed of two separate parts [A] and [B] and they get shipped mounted to each other using screws [C] (2X);

Remove screws [C] (2x) to separate the two parts [A], [B];

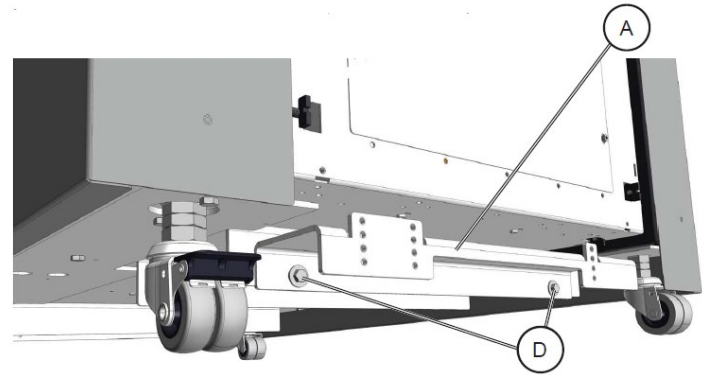

Install the first part [A] of the Docking Bracket on the VFX using screws [D] (2X);

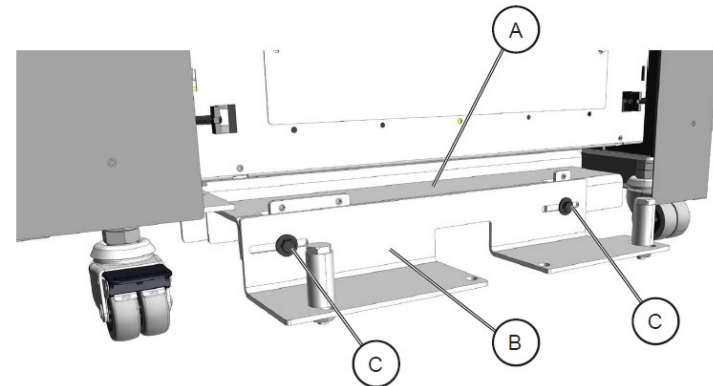

Install the second part of the Docking Bracket [B] on the first part of the Docking Bracket [A] by using the screws [C] (2x).

Push the StreamPunch VFX directly upstream so StreamPunch VFX Upstream Docking Bracket slides on and locks into the pins of the Plockmatic feeder VFX Downstream Docking Bracket.



StreamPunch VFX Upstream Docking Bracket



StreamPunch VFX docking into Plockmatic VFX

If you will be attaching the StreamPunch VFX to the eWire VFX, refer to the eWire VFX installation section.

If the StreamPunch VFX is the end device, proceed to Cable Connections.

8.2.4 Connection and Powering the StreamPunch VFX

Do the following to power up the StreamPunch VFX.

1. Check the specifications of the input power to StreamPunch VFX is 115/230v 50/60 Hz.
2. Connect the ground cable between the StreamPunch VFX and Plockmatic VFX.

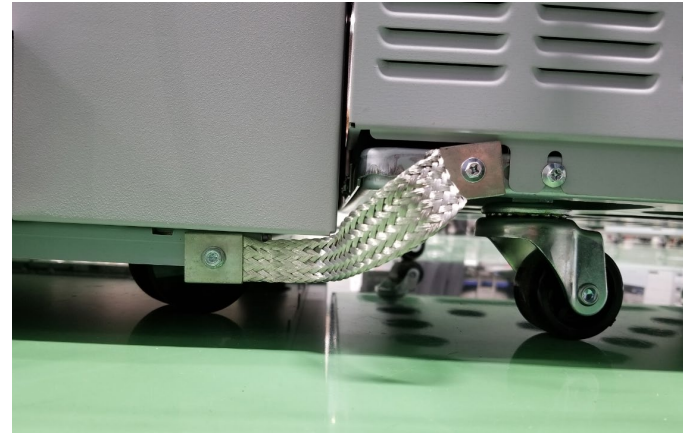

3. Connect the COMM Cable to the COMM Port of the VFX.



4. Connect the other end of the COMM Cable to the top DFA Port of the StreamPunch VFX.



5. Connect the Power Cord to the Power Inlet on the rear of the StreamPunch VFX. Turn the power switch inside the front door of the StreamPunch VFX on.
6. Configure the StreamPunch VFX as the End Device.
 - Settings > Enter Service Mode > Enter Code 442 (Or 12345 if that does not work) > Options 1 > Select “Yes” for DFA End Device

8.3. eWire VFX Installation

This section contains installation instructions regarding the unpacking and setup of the eWire VFX.

8.3.1 Check the Packing List

The eWire VFX shipping material should contain 1 box with a wooden board on top:

- Pallet with eWire VFX.
- Wooden board used as unloading ramp

The fully packed eWire VFX measures 1270mm H x 1090mm W x 920mm L (50in H x 42.9 in W x 36.2 in L) and weighs 274 kgs (605 lbs)

8.3.2 Upstream Device Requirements

The StreamPunch VFX system must be installed upstream of the eWire VFX. The eWire VFX needs to be directly attached downstream from the StreamPunch VFX.

8.3.3 Required Tools

The following tools are required to unpack and install the eWire VFX.

- Utility knife or box cutter
- 17mm and 19mm open end wrenches
- 10mm socket wrench
- 7mm socket wrench or nut driver
- 200 gsm (or heavier) paper

8.3.4 Remove the Packing Materials

Do the following to remove all packing materials from the eWire VFX.

1. Clear the space needed for the eWire VFX.
2. Move the Shipping Container into position near where you will install the eWire VFX



3. Remove the plastic shrink-wrap from the container and remove the packing Straps.
4. Remove the wooden ramp from the top of the shipping container. Do not discard the wooden ramp. It will be needed later to remove the eWire VFX from the pallet.
5. Remove any additional packing from inside the top of the box.

6. Remove cardboard outer package by lifting it straight up off the eWire VFX. Take care not to scrape the sides of the machine. Note: Two people should work together to lift the outer packaging, which is one large piece.
7. Remove the inner shrink wrap covering the eWire VFX.

8. Open the element feeder door on the front left of the machine. Locate the shipping bracket at the bottom of the frame. Remove the M6 screw and remove the clamp plate from bracket. Remove the 2 x M10 bolts securing the support bracket to the pallet and remove the shipping bracket from the eWire VFX.
9. Repeat this procedure for the bracket located under the electrical panel at the rear of the machine.
10. Locate the shipping bracket on the left side of the machine. Remove the 3 x M6 screws securing the side bracket to the eWire VFX. Remove the 5 x M10 bolts securing the shipping bracket to the pallet. Slide the bracket out from under the eWire VFX and remove it.



11. Repeat for the opposite side bracket.
12. Remove the blocks and bolts (7723183 and 7709668) from the element feeder drawer. Place the ramp support blocks under the pallet, lining up the holes in the blocks with the holes in the pallet.





- Place the wooden ramp onto the appropriate location on the front of the pallet. Secure the ramp in place using 2 long screws or Allen wrenches.



- Using two people, carefully push the eWire VFX from the back down the ramp. Make sure the eWire VFX casters stay on the pallet and the ramp and control the machine on the way down. Make sure to support the eWire VFX carefully while moving due to its weight.
- Open the top cover and lift the lower bypass panel. Remove the shipping material in the book draw so that the drawer can open. Open the book drawer and remove the contents. Check all the parts are

present before proceeding.



- | | |
|---------|---|
| 6200001 | CORD SET, 115V |
| 6200002 | POWER CORD, EUROPE |
| 6200014 | POWER CORD, UK |
| 6200015 | POWER CORD, SWISS |
| 7717770 | INFEED GUIDE ASSEMBLY, FWD, EWIRE VFX |
| 7718170 | DOCKING PLATE, SPARTA TO EWIRE VFX |
| 7716522 | CD, OPERATOR AND INSTALLATION MANUALS |
| 7718072 | FLEXIBLE MAGNET, ASSY, EWIRE VFX |
| 7717869 | CABLE, DATA, EXTERNAL, EWIRE VFX |
| 1823903 | SCREW, PHILLIPS HX HD W/SEMS M4 X 8 (Qty 8) |
| 7718208 | CABLE, LAN, COMMUNICATION |
| 7708460 | MIDWAY SHUNT CABLE |
| 7717880 | COVER, USB DRIVE, EWIRE VFX |
| 7723152 | WIRE CUTTERS |
| 7717879 | TOOL, PUNCHED HOLE POSITION CHECK |
| 7717881 | EWIRE VFX SETUP TOOL ASSEMBLY, ELEMENT HEIGHT |
| 7709668 | SCREW, CARRAIGE, 5/16-18X4" (Qty 2) |
| 7723183 | SUPPORT, PACKING, EWIRE VFX |

- Using the wire cutters from the installation kit, remove the red cable tie from the handle. Lift the handle on the Vacuum Module and remove the bubble wrap from beneath the Vacuum Module.

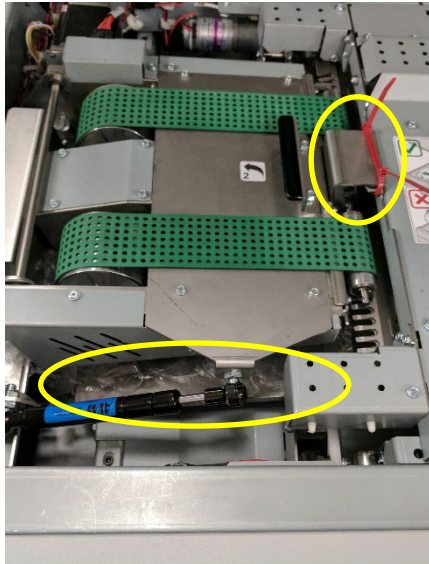

17. Remove the zip tie from the Drawer Lockout mechanism where shown.

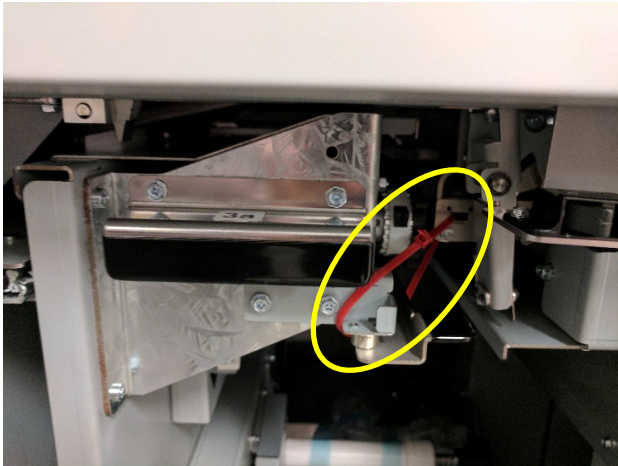

18. Remove the zip ties securing the closer module the side frame of the eWire VFX.

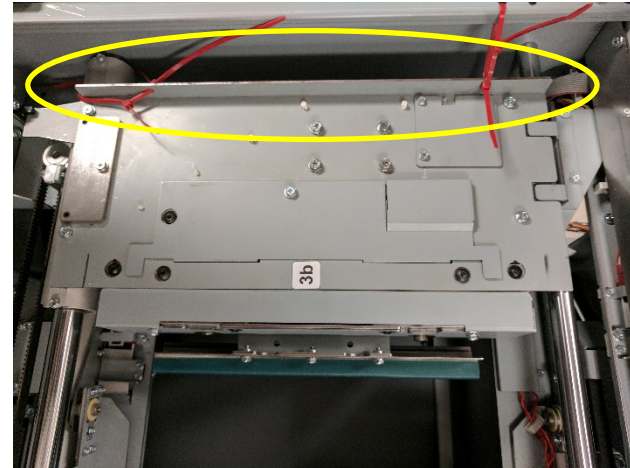

19. Move the closer module by hand to reveal the cable tie on the holder frame. Remove the cable tie.

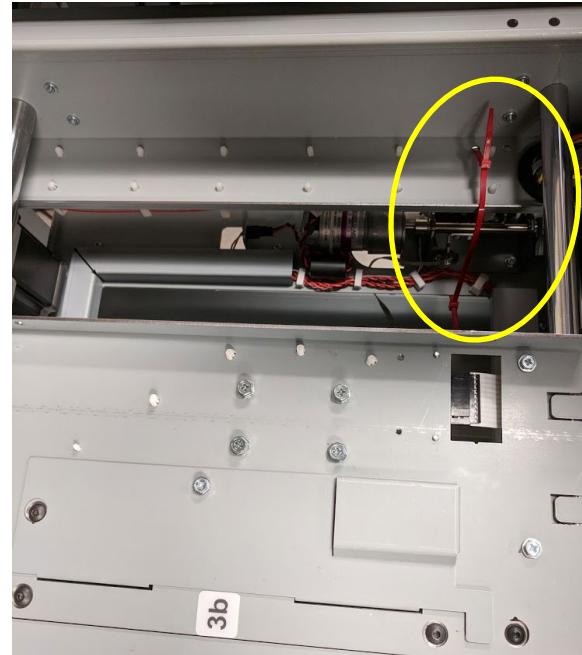

20. Remove the foam shipping blocks from the front and rear that keeping the holder in place.

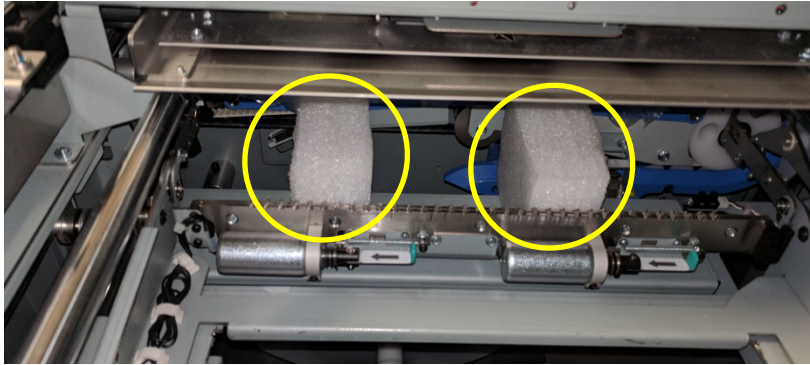

21. Place the spare magnet strips from the installation kit on the element feeder as shown below. When storing them on the element feeder, ensure that they are completely on the flat face of the drawer and are not near the spool.

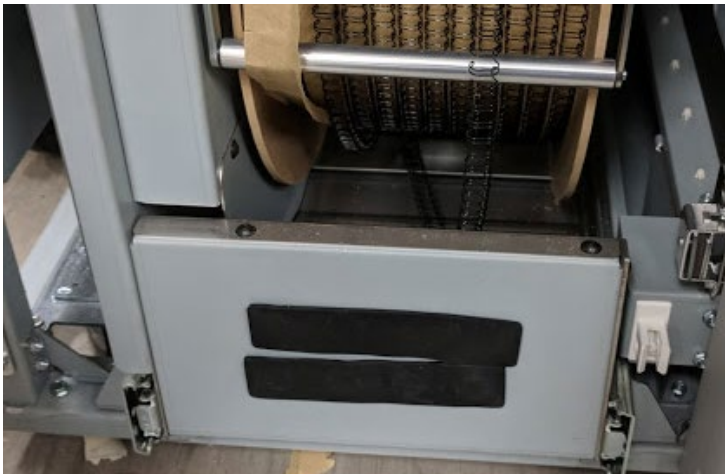

22. Take the wire cutters from the installation kit and install them into the triangular pocket located behind the element feeder door. Place the Element Height Setup Tool and the Punched Hole Position check tool on the inside of the book drawer as shown below.

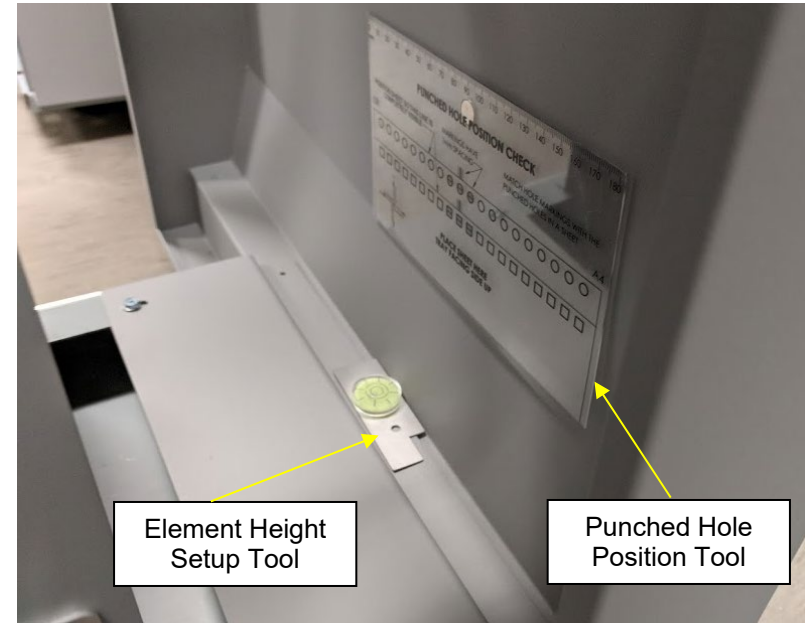

8.3.5 Inspect for Damage

23. Inspect the entire machine for damage. Make sure any damage that could affect the operation of the eWire VFX is repaired.
24. Double check that all packaging (foam, zip ties, lock collars) has been removed from the eWire VFX. Running the eWire VFX with packaging material still in place could cause damage.

8.3.6 Prepare and Dock

1. Locate the docking plate for the upstream StreamPunch VFX that was removed from behind the book drawer door.
2. Remove the M4 screw locking the docking latch to the eWire VFX and set it aside for later. Pull Docking Latch to unlock Docking Latches.



3. Mount the docking plate to the upstream StreamPunch VFX device with the (4) M4 screws as shown below.



4. Set the plate so the middle marking is in line with the screw.



- Remove the existing anti-static brush and any excessive adhesive with alcohol and a rag from the StreamPunch VFX Exit Plate.

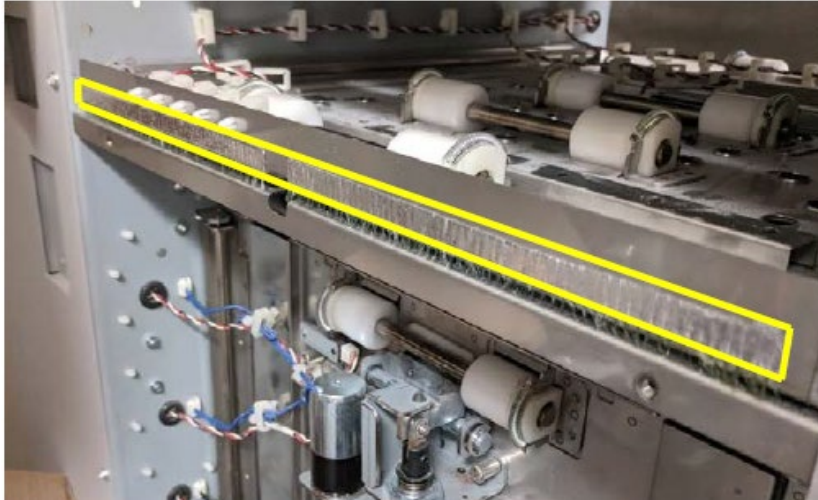

- Attach the Outfeed Guide (7717770) from the installation kit with (2) M4 screws provided in the installation kit.



- Before docking, ensure that the paper path outfeed guide on the StreamPunch VFX is level with the infeed guide on the eWire VFX. The paper path center line of the StreamPunch VFX outfeed guide should be vertically aligned with the center of the eWire VFX infeed. Adjust the casters of eWire VFX as necessary to achieve this. Refer to ADJ 1.12 in the service manual for instructions on caster adjustment.

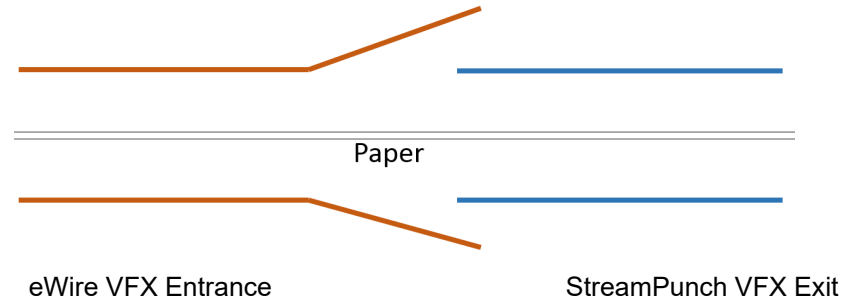

8. Line the alignment pin on the StreamPunch VFX mounting plate with the slotted hole on the eWire VFX docking bracket.



9. After the machine is aligned with StreamPunch VFX, push the eWire VFX upstream to engage the docking mechanism on the eWire VFX with the brackets on the STREAMPUNCH VFX.

10. Check that the sensor window at the exit of StreamPunch VFX aligns with the entrance sensor window of the eWire VFX.

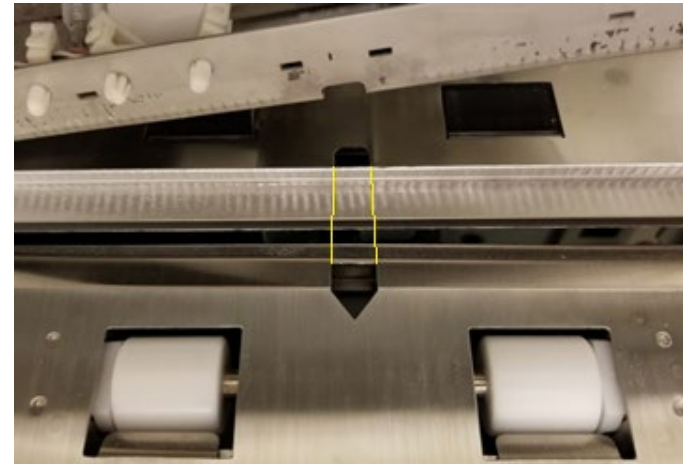

11. If the sensor windows do not align repeat step 4 and adjust the position of the docking plate. Adjust the plate position until the sensor windows are aligned.
12. Once docked, engage the docking lock by pushing the bracket in and securing it with the M4 screw removed on step 2.

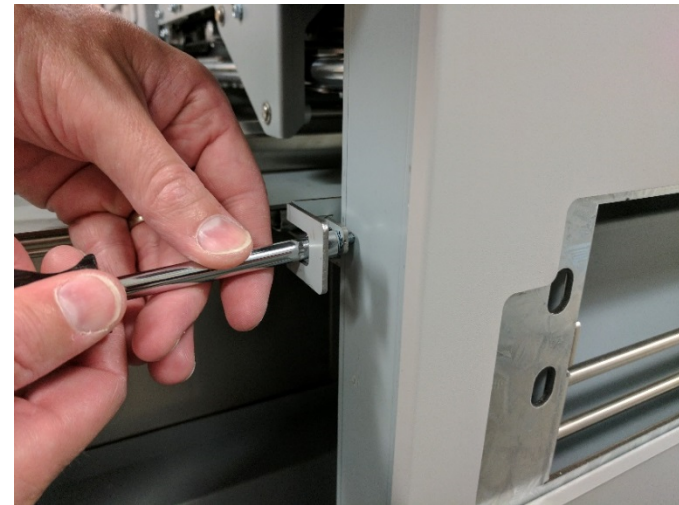

8.3.7 Vertical Alignment and Leveling of the eWire VFX

25. While maintaining the proper paper path height shown in section 8.5, adjust the height of the upstream casters of the eWire VFX so that the top cover of the eWire VFX is the same height as the top cover on the StreamPunch VFX. Refer to ADJ 1.12 in the service manual for instructions on caster adjustment.
26. Check the level of the eWire VFX front to rear on the upstream side of the top cover. Make adjustments to the upstream casters as necessary to level them while maintaining the correct paper path height.



27. Check the level of the eWire VFX left to right. Adjust the downstream casters as necessary to level the machine in this direction.



28. Recheck the level of the front to back level of the cover at the upstream and downstream edges, and correct any level issues these may be off after performing step 3.

29. Dock the eWire VFX to the upstream device and look through the gap on the upstream side of eWire VFX. Confirm that the exit baffles of the upstream device are aligned vertically with the infeed baffles of the eWire VFX. A piece of thick paper (200gsm or heavier) can be fed through the StreamPunch VFX into the eWire VFX to better visual the height alignment.

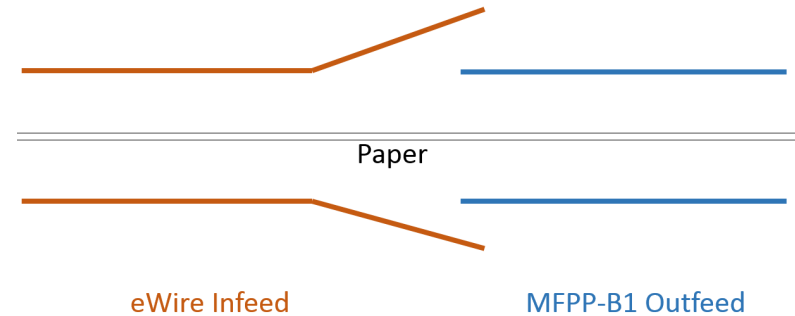

30. Once the eWire VFX is the proper height and level, lock the casters in place as outline in ADJ 1.12

8.3.8 Connections and Powering the eWire VFX

Do the following to power up the eWire VFX.

31. Check the specifications of the input power to eWire VFX is 115/230v 50/60 Hz.
32. Connect the ground cable between the eWire VFX and finisher

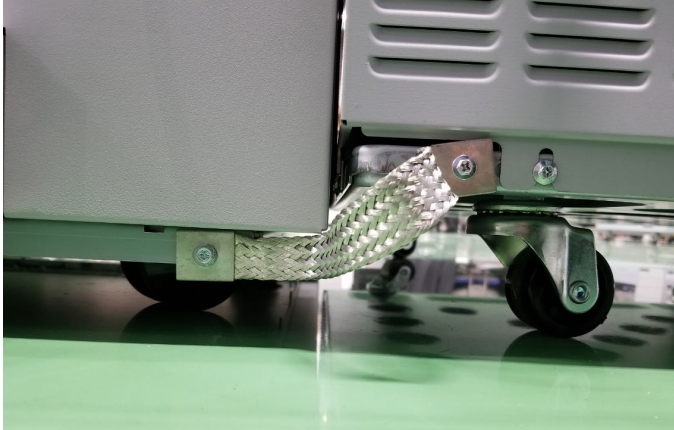

33. Connect the shunt cable 7708460 between the StreamPunch VFX and the eWire VFX



34. Connect the Power Cord to the AC Filter on the rear of the eWire VFX.
35. Remove the connector covers from eWire VFX and the StreamPunch VFX.

36. Replace the cover from the StreamPunch VFX with the extra cover found in the installation kit.
37. Thread the communication cable through the hole in the covers on each end.



38. Plug in the cable and replace the covers onto the eWire VFX VFX and StreamPunch VFX.



StreamPunch VFX

eWire VFX

39. Plug in the COMM Cable to the Bottom DFA Port of the StreamPunch VFX and the other end to the Top DFA Port of the eWire VFX.



40. Press the Power Switch to the On (I) position.
Once the full system is powered check the eWire VFX LCD shows READY. If no element spool is installed the LCD will show ADD ELEMENTS.

8.3.9 Configure the eWire VFX

41. Do GP 6.2.4 LANGUAGE MODE Procedure to set the desired language.
42. Configure the eWire VFX as the end device.
- Enter Service Mode > DFA State > Press Enter > Select Yes for End Device? > Press Enter

8.3.10 Run eWire VFX

43. Do GP 6.7 or refer to the user manual Section 6.B to install a supply spool.
44. Run a simple bypass job from the printer and check that the sheets transition correctly from upstream and downstream of eWire VFX.
45. Complete the HOLDER TO XFER function test described in GP 6.3.4. Make sure the holder mates flush with the element feeder. Follow ADJ 1.3 and ADJ 1.16 if adjustment is needed to remove any gaps.
46. Feed an element per the function FEED ELEMENT test described in GP 6.3.4. Make sure the element feeds and moves to the stack

position without issue. Check that the height of the element at the front and rear, in relation to the deflector, is the same using the element height tool described in ADJ 1.10.

47. Perform the Element Hook Position Adjustment ADJ 1.8 to make sure the alignment, skew and deflector timing are correct. The deflector timing can be done for every element size. Once the alignment and deskew is checked/adjusted for one element size it should not need to be done for other sizes.
48. Program the printer to feed a book job into the eWire VFX and confirm that the eWire VFX successfully creates a book.

8.3.11 User Manual

Make sure the customer has the *User Instructions Manual*.

Review the following sections of the user manual with the user to ensure they are familiar the operation and basic troubleshooting procedures. User knowledge of the sections indicated below will reduce jams and the need for service calls.

Section 7 – User Operations

- A. Removing a supply spool from the machine
- B. Installing a new supply spool into the machine
- C. Supply spool storage
- D. Emptying the book drawer
- E. Clearing jams

Section 9 – Problem Solving

This area lists the most likely causes of jam codes and errors. Review with the user the possible problem areas shown in the table in Section A

Point out the location of S22 sensor and the element slack sensor.

Ensure that no debris fell under the element slack sensor during the installation. Demonstrate to the user how to check and clean this area when you perform this check during the installation.